

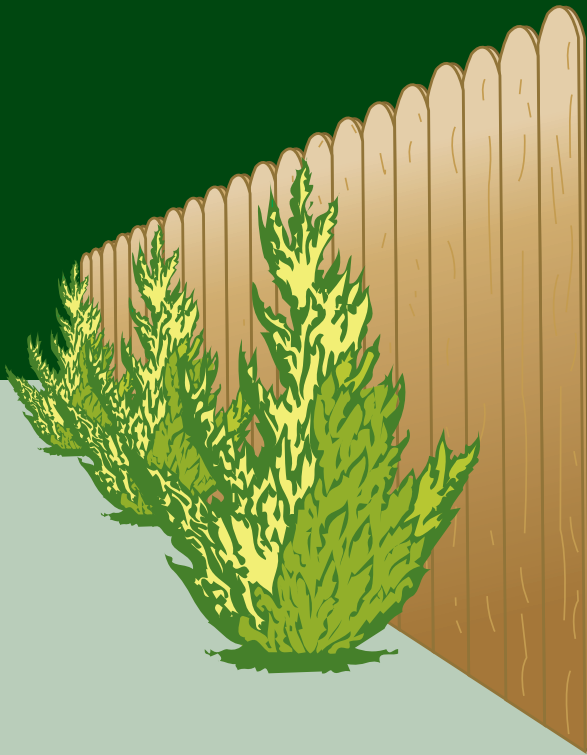

Build your own

Treated Pine **DIY FENCE**

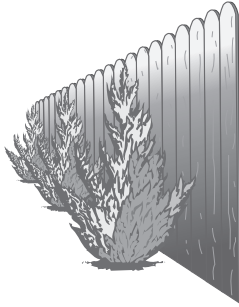



1 Getting Started

Corner and finishing posts should be erected first. The centre of the post should be positioned over the line of the fence. The tops of these posts should be set at the required height of the fence above the ground. A paling may be used as a height gauge and any excess height should be cut off the bottom of the post.

Using a steel measuring tape, the length of the fence may now be divided into panels (the distance between two adjacent posts). The panel widths should not exceed 2.4 metres and wherever possible should be adjusted to increments of 300mm. (The basic length module used by the timber industry).

The post hole centres may be marked with small pegs partially driven into the ground. The centres of the post holes have now been located in a longitudinal direction (i.e along the line of the fence). They have to be aligned in a lateral direction.

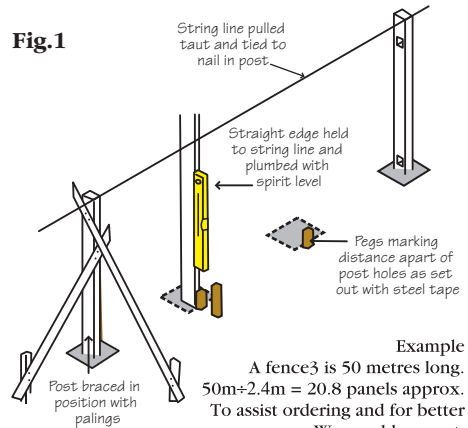

Example
A fence is 50 metres long.
 $50\text{m} \div 2.4\text{m} = 20.8$ panels approx.
To assist ordering and for better appearance. We would suggest:
 $17 \text{ panels} @ 2.4\text{m} = 40.8\text{m}$
 $4 \text{ panels} @ 2.3\text{m} = 9.2\text{m}$

 50.0m

On a flat site, free of shrubs, long grass etc. it is a simple matter to run a second string line across the face of the posts at the bottom and mark the lateral position of the post holes. Such conditions are rare and it will probably be found that the method shown in Fig.1 will need to be adopted.

A straight edge (a straight paling is satisfactory) and spirit level are positioned as in Fig.1. Adjust the bottom of the straight edge until the spirit level reads plumb. Now adjust the peg to the side of the straight in a lateral direction only.

DO NOT REMOVE IT IN A LONGITUDINAL DIRECTION.

Repeat this procedure at every peg and adjust the pegs where necessary.

2 Excavation

The post holes may now be excavated to a recommended depth of about 600mm.

NB

The whole of your careful setting out will be wasted if these post holes are not excavated accurately.

Excavate the hole with the peg as its true centre. Keep the 4 sides straight and absolutely plumb vertically – otherwise it will be impossible later to align the posts and the appearance of the fence will suffer. A little extra time spent in this area will pay dividends later.

Try not to over excavate the depth of the hole. If you do, be sure and compact the filling put back in the hole to correct this by ramming, or later settlement of the post will occur.

3 Post Erection

You must decide what contour the top of the fence is to follow. On a flat site, it will obviously be straight and parallel to the ground.

On a sloping site or one having marked changes of contour, the method shown in Fig. 2 is usually adapted.

The palings or height gauges can be adjusted until a pleasing line has been achieved.

With the string line adjusted to its final heights the posts may now be cut to length. Place a post adjacent to each hole. Place the post upside down in the hole and mark a line on the post, corresponding to the height of the string line. Cut off the excess.

Repeat this procedure with all the posts and number each post to correspond with its intended position.

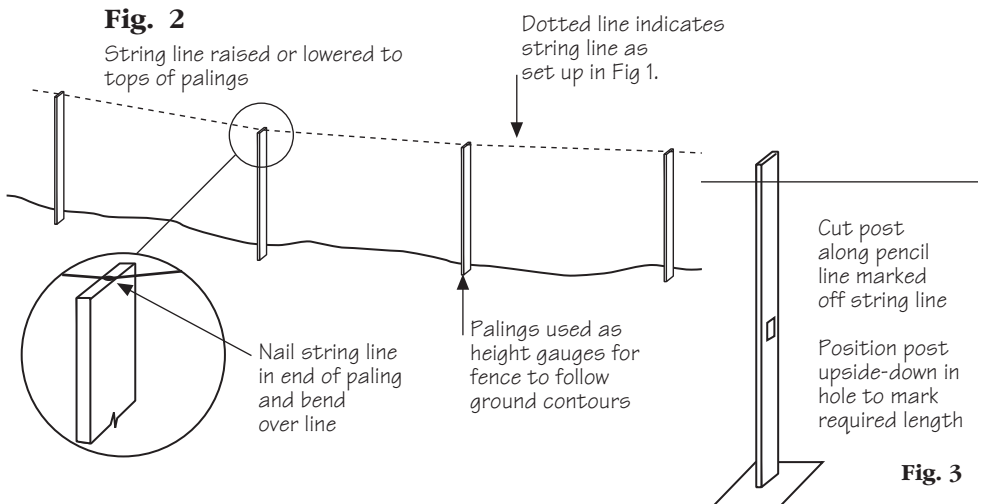

4 Rail Erection

If correct ordering procedure has been followed, the length of each rail will be two panel widths (eg. two 2.4 metre panels followed by a 2.3 metre panel will require a 4.7 metre rail – which of course, would have to be purchased as a 4.8 metre length of timber and re-cut).

Having chosen your method of joining the rails, now cut one rail only to the 1st panel width and cut one end to the required joint. Leave the second rail uncut. Where 3 rails are used, the

centre rail can be the rail cut to the 1st panel width and the top and bottom rails left uncut.

Test every mortice in each post to ensure that the rails are a sliding fit.

Commencing from one end of the fence, fix the half rail to the end post ensuring that the second post is at its correct spacing and follow the various procedures outlined in Fig.5 repeating the whole operation until the last rail has been fitted into position.

AT THIS STAGE DO NOT BACK-FILL THE POST HOLES

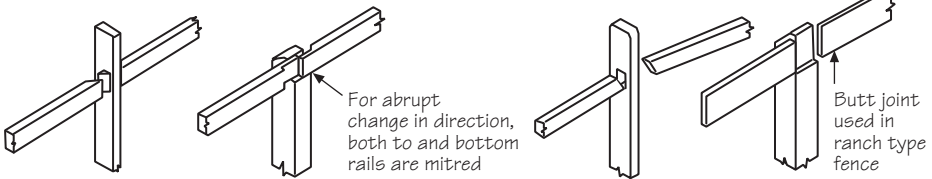

Fig. 4

AT THIS STAGE DO NOT BACK-FILL THE POST HOLES

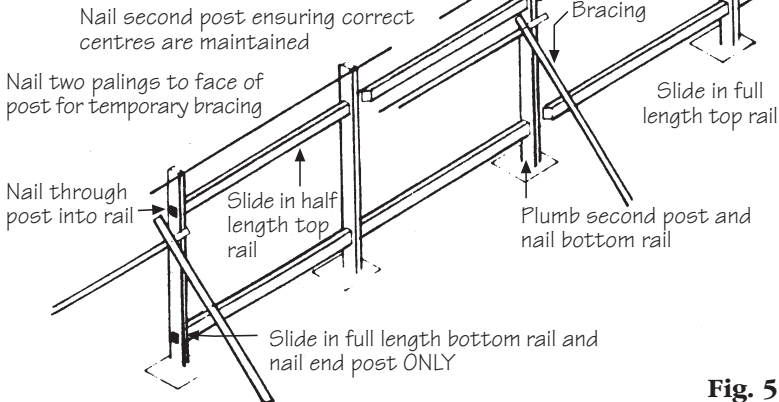

Fig. 5

5 Cladding

The sawn palings must be secured in a line with the string line and each member kept plumb. This can be spot checked with the spirit level (See Fig. 6). Repeat these procedures with each panel and finish all nailing.

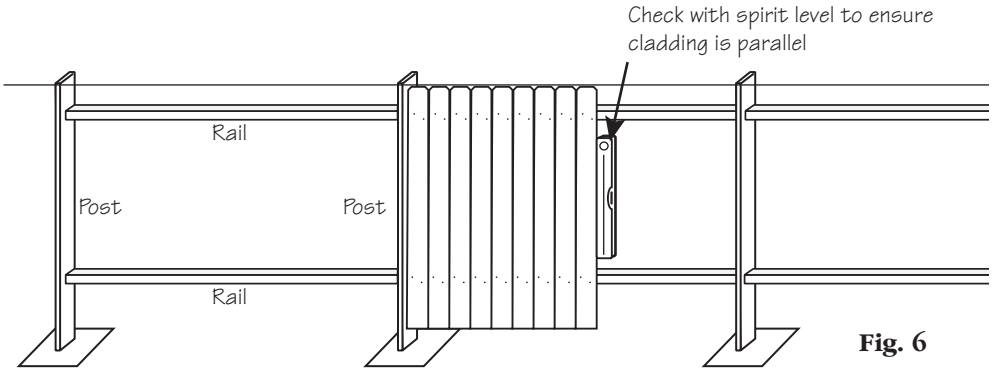

Fig. 6

6 A Good Neighbour Fence

The decision to erect a boundary fence usually involves discussion as to which of the adjoining properties will face the palings. One way to avoid neighbourly disagreement is to develop a fence style which looks good from both sides.

One easy way to achieve this, is to fix spaced palings on both sides of the rails. The high privacy gained by a normal close-butted paling fence would be reduced, but the spacing between palings on both sides can be adjusted to give adequate privacy with an advantage that cooling breezes can still penetrate.

After erection of the screen/fence frame the first row of palings is fixed, spaced along one side of the fence rails. Spacing could be varied to improve final privacy (eg. using 150mm wide palings, the spacing could be 100mm).

The second row of palings is then fixed to the back of the rails so that the view through the space palings is blocked. If more privacy is demanded then the 150mm wide palings on both sides would be spaced 50mm.

Osmose Australia. makes no warranties expressed or implied or as to the fitness for a particular purpose of this plan. Check with an architect, building expert or soil engineer to make sure that this plan is appropriate for your situation and meets local building codes. A permit may be required. Read carefully the important timber information on www.osmose.com.au <<http://www.osmose.com.au>> regarding pressure treated wood before starting construction.

7 Capping a Fence

The end grain of posts and palings are exposed to the hazards of wind rain and dew can reduce the long-term durability of the fence and increase the need for maintenance.

Protection for the end grain of posts and palings can be provided by a slightly different frame structure, which would include a cap rail fixed to the tops of the posts and upper rail.

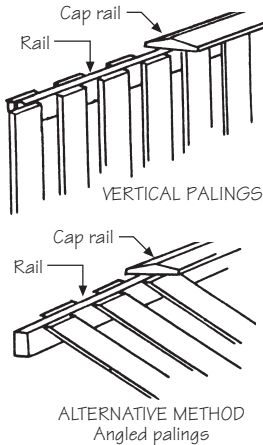

How to shape a rounded arch

1) Determine height of arch (1/5 panel width recommended) and mark down from top of panel, 'YY' line on diagram. Mark mid point of panel width (M on diagram) for top point of arch.

2) With an offcut the length of half the panel width, rotate from point 'M' to intersections with 'YY' line. Mark intersection points (F on diagram). Drive nails into 'F' and 'M' points half way into panel.

3) Tie string to one 'F' point, loop over 'M' point and with string line taut tie to the other 'F' point.

4) Remove 'M' nail. Position pencil in string loop and starting at one 'Y' point keep string taut at all times, trace out the arch ending up at the other 'Y' point.

5) For a reverse arch position 'M' point on 'YY' line and 'F' points on top of panel (marked XX). Arch is then traced from one 'X' point to other 'X' point.

Best effect is achieved with equal width panels.

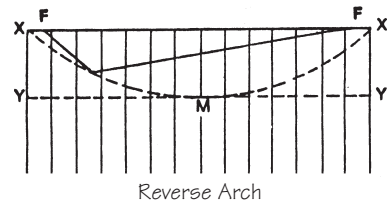
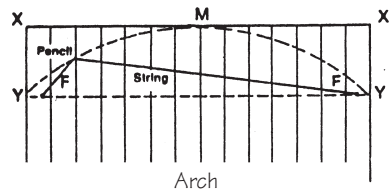

Timber care

Cutting, notching or boring may expose untreated heartwood.

A liberal coating of PROTIM® RESEAL is recommended to restore the protective envelope. For more details refer to the PROTIM® Timber care product literature. Raincoat UV Plus should be used to reduce the effects of weathering & maintain the appearance of your timber project.



Important Information

1. Do not burn preserved wood.
2. Wear dust mask & goggles when cutting or sanding wood.
3. Wear gloves when working with wood.
4. Some preservative may migrate from the treated wood into soil/water or may dislodge from the treated wood surface upon contact with skin. Wash exposed skin areas thoroughly.
5. All sawdust and construction debris should be cleaned up and disposed of after construction.
6. Wash work clothes separately from other household clothing before re-use.
7. Preserved wood should not be used where it may come into direct or indirect contact with drinking water, except for uses involving incidental contact such as fresh water docks and bridges.
8. Do not use preserved wood under circumstances where the preservative may become a component of food, animal feed or beehives.
9. Do not use preserved wood as mulch.
10. Only preserved wood that is visibly clean and free of surface residue should be used.
11. Do not use preserved wood in direct contact with aluminum.
12. If the wood is to be used in an interior application and becomes wet during construction, it should be allowed to dry before being covered or enclosed.
13. Disposal Recommendations: Preserved wood may be disposed of in landfills or burned in commercial or industrial incinerators or boilers in accordance with federal, state and local regulations.
14. If you desire to apply a paint, stain, clear water repellent or other finish to your preservative treated wood, we recommend following the manufacturer's instructions and label of the finishing product. Before you start, we recommend you apply the finishing product to a small exposed test area before finishing the entire project to insure it provides the intended result before proceeding.
15. Certain metal products (including fasteners, hardware and flashing) may corrode when in direct contact with wood treated with copper-based preservatives. To prevent premature corrosion and failure it is important to follow the recommendations of the manufacturers for all metal products.
16. Mould growth can and does occur on the surface of many products, including untreated and treated wood, during prolonged surface exposure to excessive moisture conditions. To remove mould from the treated wood surface, wood should be allowed to dry. Typically, mild soap and water can be used to remove remaining surface mould. For more information visit www.epa.gov.
17. For more information visit www.osmose.com.au / www.osmose.co.nz.

HAZARD CLASS	CONDITIONS	HAZARD	EXAMPLES
H1	Completely protected from the weather and well-ventilated	Lyctid borers	Susceptible framing, flooring, furniture and interior joinery
H2	Protected from wetting	Borers including termites	Framing, flooring and similar, used in dry conditions
<p>H2F - Conditions and biological hazard as for H2 although approved for use Souther of the Tropic of Capricorn only. Example: Envelope Treatment</p> <p>H2S - Conditions and biological hazard as for H2 although approved for use Souther of the Tropic of Capricorn only. Example: LVL/Plywood (glue-line treatment)</p>			
H3	Subject to periodic moderate wetting	Moderate decay fungi, borers and termites	Weatherboard, fascia, pergolas (above ground), joinery, decking & laminated verandah posts
H3**	Products predominantly in vertical exposed situations and intended to have the supplementary paint coat system that is regularly maintained.	Moderate decay fungi, borers and termites	Fascia, barge boards, exterior cladding, window joinery, door joinery and non laminated verandah posts
H4	Subject to severe wetting	Severe decay fungi, borers and termites	Fence posts, garden walls less than 1 m high
H5	Subject to extreme wetting and/or where the critical use requires a higher degree of protection	Very severe decay fungi, borers and termites	Retaining walls, piling, house stumps, building poles and cooling tower fill
H6	Subject to prolonged immersion in sea water	Marine wood borers and decay fungi	Boat hulls, marine piles, jetty cross bracing and landing steps etc

Note: Please refer to the complete standards for more detailed information.

** as per AS1604 and NSW TMA

*For further information see separate brochure, consumer information and handling guide and guarantee documents.

PROTIM®, RESEAL® and MoistureGuard™ are trademarks of Osmose, Inc. or its subsidiaries. © 2009 Osmose Australia.

442 Binstead Way, GAVEN, QLD 4210

Ph: 07 5573 1244 | Fax: 07 5573 2337 | E: info@pinewoodproducts.com.au